

## Supply Valves

### Model 180

#### Supply Valve

- For one or two-pipe steam or water heating systems
- Non-modulating
- Brass construction
- Non-rising handle with spring packed construction
- Angle and straightaway patterns available
- Available in sizes 1/2" - 2" (15-50mm) NPT
- Operating pressure:
  - 25" (635mm) Hg vacuum to 150 psig (10.3 bar) for steam service
  - 150 psig (10.3 bar) maximum for water service
- Maximum pressure 150 psig (10.3 bar)



Supply Valve  
Model 180

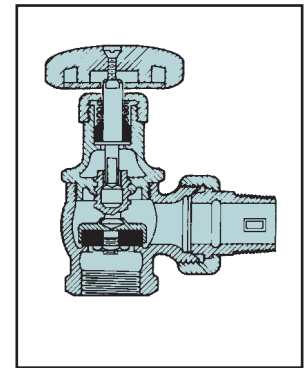

### Model 184

#### Packless Supply Valve

- For vacuum, steam and water heating systems
- Modulating with dial and pointer
- Brass construction
- Non-rising handle; packless construction
- Angle and straightaway patterns available
- Available in sizes 1/2" - 3/4" (15-20mm) NPT
- Operating pressure:
  - 25" (635mm) Hg vacuum to 125 psig (8.6 bar) for steam service
  - 125 psig (8.6 bar) maximum for water service
- Maximum pressure 125 psig (8.6 bar)



Packless  
Supply Valve  
Model 184

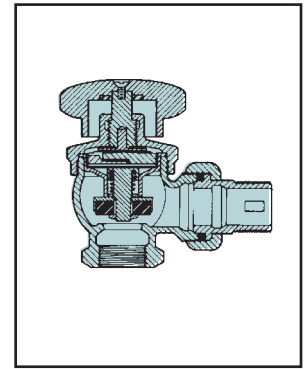

### Model 185

#### Supply Valve

- For two-pipe steam and water systems
- Modulating with dial and pointer
- Brass construction
- Non-rising handle with spring packed construction
- Angle and straightaway patterns available
- Available in sizes 1/2" - 1 1/2" (15-40mm) NPT
- Operating pressure:
  - 25" (635mm) Hg vacuum to 150 psig (10.3 bar) for steam service
  - 150 psig (10.3 bar) for water service
- Maximum pressure 150 psig (10.3 bar)



Supply Valve  
Model 185

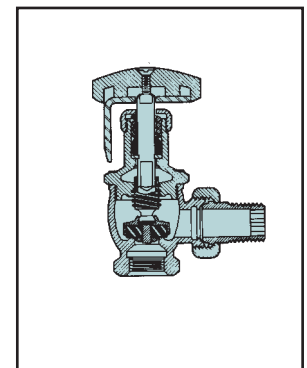

### Model 187

#### Supply Valve

- For one or two-pipe steam or water systems
- Non-modulating
- Brass construction
- Angle pattern only
- Available in sizes 1/2" - 2" (15-50mm) NPT
- Operating pressure:
  - 125 psig (8.6 bar) for steam service
  - 50 psig (3.5 bar) for water service
- Maximum pressure 150 psig (10.3 bar)



Supply Valve  
Model 187

