

Pressure and/or Temperature Pilot Operated Steam Regulators (continued)

Series 240 PNT For Control Quality Air

The Model 240 PNT Pneumatic Temperature pilots are designed for applications such as offices, schools, hospitals, or others where the unit will operate with a pneumatic temperature control system. The Model 240 PNT is specifically designed for the low air consumption required in such systems. They are also recommended for environments requiring rapidly changing loads or close temperature control. **An Air Pressure Pilot, an Air PRV Regulator and a Series 2000 Main Valve Steam Regulator *must* be used with the Model 240 PNT.**

- Low air consumption of 0.008 scfm (.00022m³)
- Calibrated temperature dial allows easy adjustment
- Copper sensing element
- Copper well (included) allows bulb removal without draining system
- Capillary length 6 ft. (1.8m)
- Supply Air Pressure
Minimum 15 psig (1.0 bar)
Maximum 30 psig (2.1 bar)
- Signal Range
0.5 psig (.035 bar) minimum outlet pressure
to within 0.5 psig (.035 bar) of supply pressure
- Temperature Control Range
-20° to 240°F (-7 to 116°C)
- Ambient Temperature Range
40° to 150°F (4 to 66°C)
- Accuracy of control ± 4°F (± 2.2°C) with system

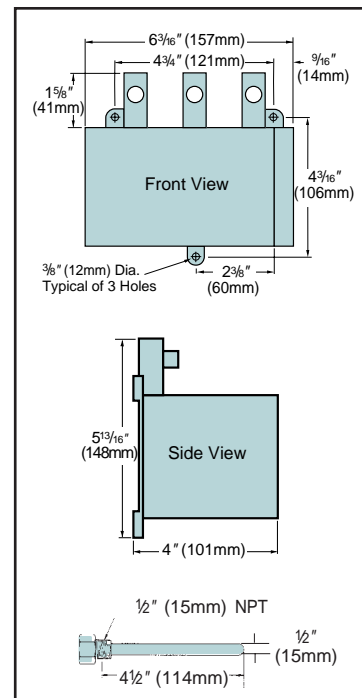
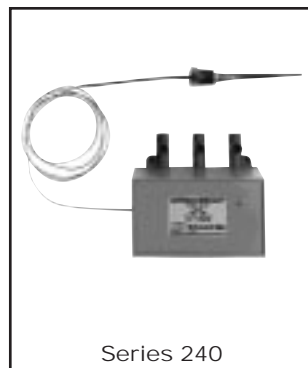

Ordering Information

Pneumatic Temperature Pilots

Model Number	Part Number	Weight (Approx.) lbs. (kg)
240 PNT	400931	3 (1.4)

Refer to Ordering Information on:

- Air Pressure Control Pilots
- Air PRV Regulators