

Self-Contained Pressure Reducing Valves

NEW
Series 754

The Series 754 is designed for applications such as commercial kitchens, labs, dry cleaners, or others that require system pressure reduction of steam in small equipment.

- For steam service
- For controlling steam pressure, where an accurate tight closing valve is required, on applications such as:
 - Small sterilizers
 - Cooking kettles or tables
 - Hand irons
 - Heating coils
 - Coffee urns
 - Unit heaters and pressing machines
- Adjustable outlet pressure
- Single seated for dead-end or continuous service
- Sizes 1/2" - 1" (15-25mm) NPT
- Maximum pressure drop 100 psi (6.9 bar) – for more than 100 psi (6.9 bar) use multiple valves in series
- Minimum reduced pressure 1 psig (.069 bar)
- Maximum non-shock pressure 250 psig (17.3 bar) at 400°F (204°C)
- Maximum temperature 400°F (204°C)

How to Size Series 754 Valves

1. Determine the available initial steam inlet pressure.
2. Determine the reduced outlet pressure required based on your equipment.
3. Determine the capacity required.
4. Apply the specifications (as determined in steps (1-3)) to the basic steam capacity table on the following page, and the information below.

To determine the maximum capacity of valve:

Multiply the Cv (Kv) number below by the capacity table basic number as determined on the following page.

To determine the Cv (Kv) required:

Divide the capacity required by the capacity table basic number as determined on the following page. Select a valve with the same or greater Cv (Kv) number.

Cv (Kv) Factors

Model	Valve Size in. (mm) NPT		
	1/2 (15)	3/4 (20)	1 (25)
754	2 (1.7)	2 (1.7)	7.5 (6.4)

Note: Sizing formulas are in accordance with Fluid Controls Institute Standard FCI 62-1.

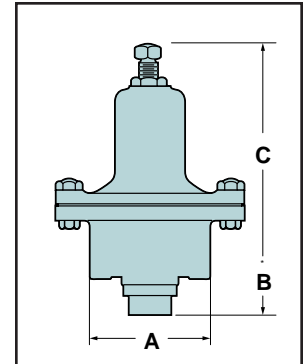

Dimensions in. (mm)

NPT Size in. (mm)	A	B	Weight (Approx.) lbs. (kg)
1/2 (15)	3 1/4 (82)	6 1/2 (165)	8 (3.6)
3/4 (20)	3 1/4 (82)	6 1/2 (165)	8 (3.6)
1 (25)	4 1/2 (114)	8 1/2 (216)	18 (8.2)

Materials of Construction	
Part	Specifications
Body	Cast Iron
Seat	Stainless Steel
Diaphragm	Phosphor Bronze
Disc	Stainless Steel
Spring	Steel-Cadmium Plated
Connections	Screwed NPT

Ordering Information

Model Number	Part Number	NPT Size In. (bar)	Outlet Pressure Range psig (bar)
754	403050	1/2 (15)	0 - 10 (0 - 0.69)
754	403051	1/2 (15)	10 - 50 (0.69 - 3.5)
754	403052	1/2 (15)	40 - 100 (2.8 - 06.9)
754	403053	3/4 (15)	0 - 10 (0 - 0.69)
754	403054	3/4 (15)	10 - 50 (0.69 - 3.5)
754	403055	3/4 (15)	40 - 100 (2.8 - 06.9)
754	403056	1 (15)	0 - 10 (0 - 0.69)
754	403057	1 (15)	10 - 30 (0.69 - 2.1)
754	403058	1 (15)	30 - 50 (2.8 - 3.5)
754	403059	1 (15)	50 - 80 (3.5 - 5.5)

Series 754 (continued)

Capacities

Basic Steam Table - Pounds Per Hour (kg/hr.)

Outlet Pressure psig (bar)	Inlet Pressure psig (bar)																			
	5 (.35)	10 (.7)	15 (1.0)	20 (1.4)	25 (1.7)	30 (2.1)	40 (2.8)	50 (3.5)	60 (4.1)	70 (4.8)	80 (5.5)	90 (6.2)	100 (6.9)	125 (8.6)	150 (10.3)	175 (12.1)	200 (13.8)	225 (15.5)		
2 (.14)	21 (9)	38 (17)	52 (23)	63 (28)	73 (33)	82 (37)	100 (45)	118 (53)	136 (61)	154 (69)	172 (78)	191 (86)	209 (94)	254 (115)	300 (136)	345 (156)	391 (177)	436 (197)		
5 (.35)		29 (13)	46 (20)	57 (25)	73 (33)	82 (37)	100 (45)	118 (53)	136 (61)	154 (69)	172 (78)	191 (86)	209 (94)	254 (115)	300 (136)	345 (156)	391 (177)	436 (197)		
10 (.7)			35 (15)	50 (22)	65 (29)	77 (34)	100 (45)	118 (53)	136 (61)	154 (69)	172 (78)	191 (86)	209 (94)	254 (115)	300 (136)	345 (156)	391 (177)	436 (197)		
15 (1.0)				37 (16)	55 (24)	69 (31)	96 (43)	118 (53)	136 (61)	154 (69)	172 (78)	191 (86)	209 (94)	254 (115)	300 (136)	345 (156)	391 (177)	436 (197)		
20 (1.4)					40 (18)	58 (26)	88 (39)	110 (49)	136 (61)	154 (69)	172 (78)	191 (86)	209 (94)	254 (115)	300 (136)	345 (156)	391 (177)	436 (197)		
25 (1.7)						43 (19)	77 (34)	107 (48)	130 (58)	154 (69)	172 (78)	191 (86)	209 (94)	254 (115)	300 (136)	345 (156)	391 (177)	436 (197)		
30 (2.1)							67 (30)	98 (44)	126 (57)	150 (68)	172 (78)	191 (86)	209 (94)	254 (115)	300 (136)	345 (156)	391 (177)	436 (197)		
40 (2.8)								74 (33)	107 (48)	125 (56)	162 (73)	186 (84)	209 (94)	254 (115)	300 (136)	345 (156)	391 (177)	436 (197)		
50 (3.5)									79 (35)	115 (52)	146 (66)	171 (77)	197 (89)	254 (115)	300 (136)	345 (156)	391 (177)	436 (197)		
60 (4.1)										82 (37)	122 (55)	154 (69)	182 (82)	247 (112)	300 (136)	345 (156)	391 (177)	436 (197)		
70 (4.8)											90 (40)	130 (58)	163 (79)	230 (104)	291 (132)	345 (156)	391 (177)	436 (197)		
80 (5.5)													95 (43)	130 (58)	214 (97)	283 (128)	345 (156)	391 (177)	436 (197)	
90 (6.2)														98 (43)	193 (87)	264 (119)	332 (150)	391 (177)	436 (197)	
100 (6.9)															168 (76)	245 (111)	315 (142)	382 (173)	436 (197)	
115 (7.9)																109 (49)	213 (96)	289 (131)	357 (161)	423 (197)
125 (8.6)																	174 (78)	267 (121)	340 (154)	410 (185)

Regulators