

Vacuum Breakers

Model 62 Part No. 401446

- For use on closed vessels and piping systems to control induced vacuum within safe limits
- Adjustable from 1/4" - 20" (8-508mm) Hg vacuum
- 3/4" (20mm) NPT straight shank
- Maximum operating temperature 366°F (186°C)
- Maximum operating pressure 150 psig (10.3 bar)

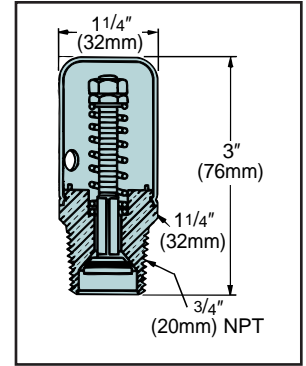

Typical Installations

