

Main Steam Vents (Continued)

Model 76 Part No. 401431

Vacuum Valve

- Float-type themostatic vent
- For medium and large one-pipe vacuum systems
- Single non-adjustable port
- ½" (15mm) NPT female and ¾" (20mm) NPT male straight shank
- Install 6-10" (150-250mm) above horizontal return and 8" (450mm) above the boiler water line
- Maximum operating pressure 3 psig (0.2 bar)
- Maximum pressure 15 psig (1.0 bar)

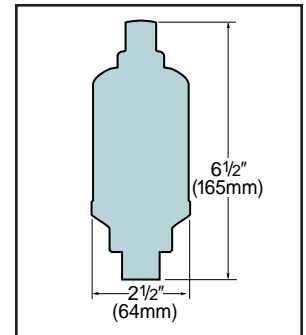

Installation

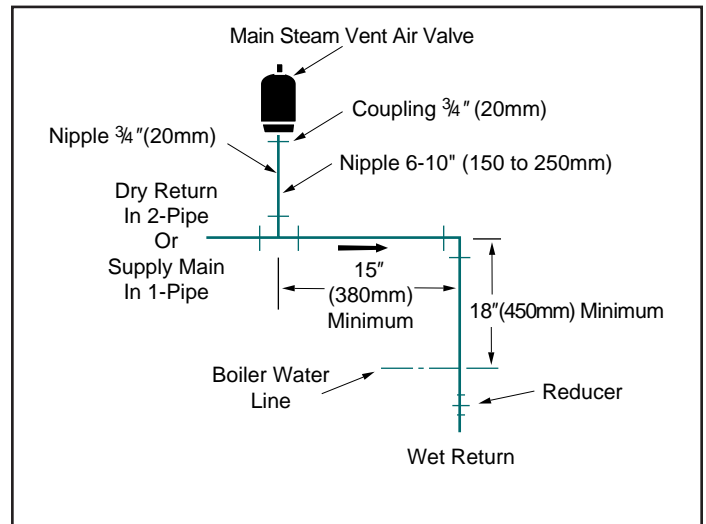

To prevent steam vents from sputtering water or damage from water hammer, observe the minimum elevations shown.