

NEW

Series 8C Balanced Pressure **BEAR TRAP®**

The Series 8C Balanced Pressure Thermostatic Steam Traps are for institutional and commercial heating system applications or others that require high capacity operation.

- Sizes available:
 - 1/2" (15mm) NPT Angle
 - 3/4" (20mm) NPT Angle or Straightaway
- Subcooling for extremely efficient system operation and elimination of flash steam losses on low pressure systems
- Replaceable Dura-Stat® module
- 3-Year Warranty
- Meets Mil specification WW-T-696-E Type V, Style A, Class 1 - 4
- Stainless steel components
- Resistant to moderate water hammer and chemical attack
- Maximum operating pressure 125 psig (8.6 bar)

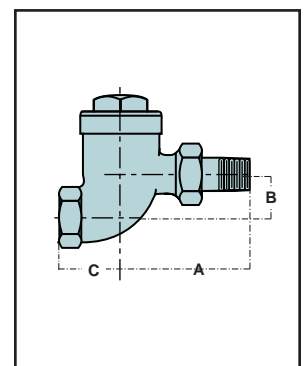
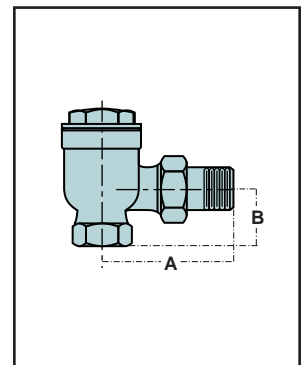
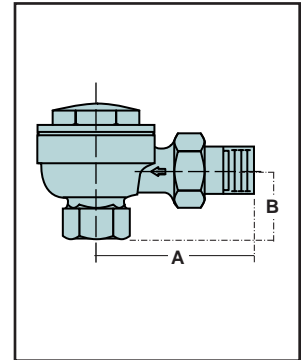

Dimensions, in. (mm)

Model	Pattern	NPT Size	A	B	C
8C	Angle	1/2 (15)	2 ²⁷ / ₃₂ (72)	1 ¹ / ₄ (32)	—
8C	Angle	3/4 (20)	3 ¹ / ₈ (79)	1 ¹ / ₂ (38)	—
8C	Straightaway	3/4 (20)	3 ⁵ / ₃₂ (80)	1 ¹ / ₈ (29)	1 ⁵ / ₈ (41)

Ordering Information

Model Number	Part Number	NPT Size in. (mm)	Differential Pressure psi (bar)	Weight lbs (kg)
8C-A-125 Angle	402002	1/2 (15)	125 (8.6)	1.5 (.7)
8C-A-125 Angle	402003	3/4 (20)	125 (8.6)	1.5 (.7)
8C-S-125 Straightaway	402004	3/4 (20)	125 (8.6)	1.3 (.6)

Gross Ratings

Series	Differential Across Trap psi (bar)											
	1/4 (.017)	1/2 (.034)	1 (.069)	1 1/2 (.10)	2 (.14)	5 (.35)	10 (.7)	15 (1.0)	25 (1.7)	50 (3.5)	100 (6.9)	125 (8.6)
8C	Capacity lbs./hr (kg/hr)											
	110 (50)	150 (68)	210 (95)	255 (116)	300 (136)	480 (218)	760 (345)	950 (431)	1350 (612)	2100 (953)	3500 (1590)	4200 (1905)

Series 8C capacities are based on 30° F (17°C) subcooling. Cold capacity is approximately 2 times capacity shown.