

Series B **BEARTRAP®**

NEW

Series B6

- Available in sizes 1½" and 2" (40 and 50mm) NPT
- Maximum capacity 20,000 lbs./hr. (9072 kg/hr.)
- Meets Mil specification WW-T-696-E Type I, Style B, Class 1-7
- Completely drains condensate and air at saturation temperature
- Stainless steel internal components
- Resistant to moderate water hammer
- Bottom inlet and top outlet
- Internal parts mounted on cover for easy service
- Maximum temperature 406°F (208°C)
- Maximum pressure 250 psig (17.3 bar)

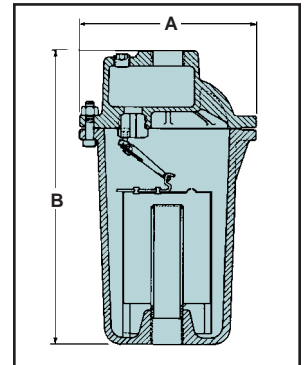

Dimensions, in. (mm)

| Series | NPT Size in. (mm) | A | B |
|--------|----------------------|-----------------|-------------|
| B6 | 1½, 2 (40, 50) | 10¾/16 (258) | 17 (432) |

| Materials of Construction | |
|---------------------------|------------------------------|
| Part | Specifications |
| Body and cover | Cast Iron 30,000 psi tensile |
| Valve Pin and Seat | Stainless Steel (Hardened) |
| Bucket | Stainless Steel |
| Lever Assembly | Stainless Steel |

Ordering Information

| Model Number | Part Number | NPT Size in. (mm) | Differential Pressure psi (bar) |
|--------------|-------------|----------------------|------------------------------------|
| B6025A | 404690 | 1 ½ (40) | 25 (1.7) |
| B6040A | 404691 | 1 ½ (40) | 40 (2.8) |
| B6125A | 404692 | 1 ½ (40) | 125 (8.6) |
| B6250A | 404693 | 1 ½ (40) | 250 (17.3) |
| B6025A | 404694 | 2 (50) | 25 (1.7) |
| B6040A | 404695 | 2 (50) | 40 (2.8) |
| B6125A | 404696 | 2 (50) | 125 (8.6) |
| B6250A | 404697 | 2 (50) | 250 (17.3) |