



# OEMIC Ball Valves

2000 WOG/PN 150 1-PIECE SCREWED END REDUCE PORT



## FEATURES

The thread ends conform to ASME B1.20.1(N P T)  
 DIN 2999 & BS 21  
 ISO 228/1 & ISO 7/1  
 NACE MR0175  
 Blow-out proof stem

APPLICABLE STANDARD	
WALL THICKNESS	ASME B16.34
TEST AND INSPECTION	API 598

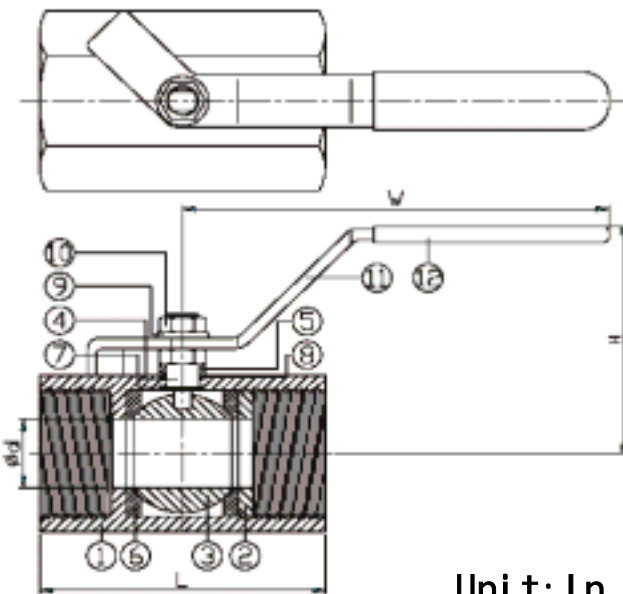

Unit: In

ITEM	PARTS	MATERIAL
1	BODY	ASTM A105
2	RETAINER	ASTM A105
3	BALL	ASTM A182/F316
4	STEM	ASTM A182/F316
5	GLAND RING	ASTM A182/F316
6	BALL SEAT	RTFE
7	BODY GASKET	PTFE
8	STEM GASKET	PTFE
9	SPRING	ASTM A182/F316
10	HANDLE NUT	AISI 1035
11	HANDLE	AISI 1020+Zn
12	HANDLE SLEEVE	BLUE PLASTIC

2000 W O G					
NPS	D	L	H	W	WEIGHT LB
1/4"	0.20	1.70	1.12	2.40	0.3
3/8"	0.28	1.86	1.32	3.39	0.3
1/2"	0.35	2.43	2.38	4.33	0.7
3/4"	0.49	2.75	2.44	4.33	0.9
1"	0.59	3.38	2.63	4.76	1.4
1-1/4"	0.79	3.69	3.25	5.75	3.1
1-1/2"	0.98	4.00	3.25	5.75	3.2
2"	1.26	4.50	3.44	5.98	5.7

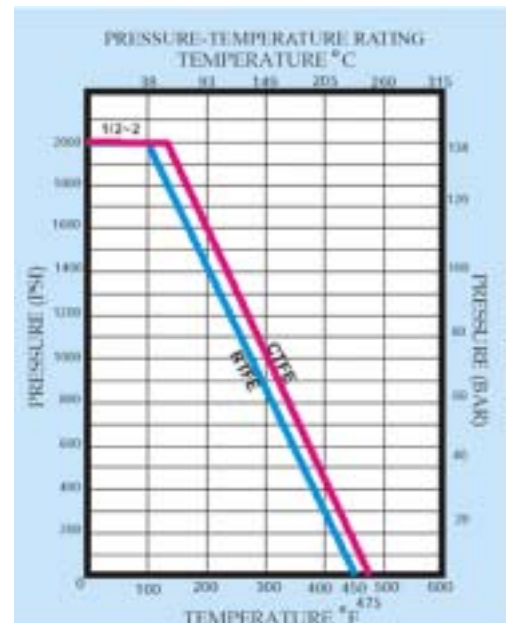

\*OEMic reserve the right to change above information without prior notice