

The Model 3350 / 3360 design is preferred by production operators and technicians worldwide for pressure control requirements, due to its simple construction, versatility, and reliable performance in the most demanding applications. The controller is offered in proportional (Model 3350) and proportional-plus-reset (Model 3360) configurations.

Features:

- **Rugged Design** – Die-cast aluminum case and cover can withstand impacts that would fracture the plastic cases of our competitors.
- **Wide Range of Bourdon Tubes** – Pressure ranges from 0–30 psig to 0–3000 psig are available. Two interchangeable ranges of output bellows and gauges (3–15 psi and 6–30 psi) are also available.
- **Simple Adjustments** – High-visibility dials are provided to assure accuracy of pressure setpoint, proportional band, and reset settings.
- **Easy Maintenance** – Simple controller design allows fast, easy maintenance and minimal spare parts inventory.
- **Field Reversible** – Switch controller action with a few simple steps. No additional parts required.
- **Easy Mode Conversion** – Add reset action to a proportional controller by simply adding a single module and three pieces of tubing.
- **Flexible Mounting Options** – Available with brackets for mounting on actuator yoke, diaphragm housing, panel, surface, or 2-inch pipestand.
- **Vibration Resistance** – Simple design and low mass of internal parts allow the controller to withstand vibration encountered in most industrial environments.
- **Low Air (Gas) Consumption** – Relay and nozzle design reduces steady-state air (gas) consumption to as low as 4.2 scfh, cutting operating costs.
- **Sour Service Capability** – Materials are available for applications handling sour gases. These constructions comply with the recommendations of NACE MR-01-75.



SPECIFICATIONS

Controller Configurations

Proportional	(Model 3350)
Proportional-plus-Reset	(Model 3360)

Input Signal (Bourdon Tube Ranges)

0 to 30 psig	(0 to 2 bar)
0 to 60 psig	(0 to 4 bar)
0 to 100 psig	(0 to 7 bar)
0 to 200 psig	(0 to 14 bar)
0 to 300 psig	(0 to 20 bar)
0 to 600 psig	(0 to 40 bar)
0 to 1000 psig	(0 to 70 bar)
0 to 1500 psig	(0 to 100 bar)
0 to 3000 psig	(0 to 200 bar)

Output Signal

3 to 15 psig	(0.2 to 1.0 bar)
6 to 30 psig	(0.4 to 2.0 bar)

Controller Action

Direct	(Increase output on increasing pressure)
Reverse	(Decrease output on increasing pressure)

Input, Supply, and Output Connections

¼ FNPT

Supply Pressure Requirements

Type:	Clean, dry air or non-corrosive gas ¹
Normal Operating Supply Pressure ² :	
3 to 15 psig output:	20 psig (1.4 bar)
6 to 30 psig output:	35 psig (2.4 bar)
Maximum Allowable Supply Pressure:	
3 to 15 psig output:	40 psig (2.8 bar)
6 to 30 psig output:	40 psig (2.8 bar)

Steady-State Air (Gas) Consumption¹

Minimum ³ :		
3 to 15 psig output:	4.2 scfh	
6 to 30 psig output:	7 scfh	
Maximum ⁴ :		
3 to 15 psig output:	27 scfh	
6 to 30 psig output:	42 scfh	

Performance

Repeatability:	0.5% of bourdon tube range
Dead Band:	0.1% of output span

Controller Tuning Adjustment Ranges

Proportional (full output pressure change):	
3 to 15 psig output:	3–100% of input range
6 to 30 psig output:	6–100% of input range
Reset:	Adjustable from 0.01 to 74 minutes per repeat (100 to 0.01 repeats per minute)

Maximum Allowable Static Pressure

Same as bourdon tube upper range value

Operating Temperature Limits

-40 to 160°F (-40 to 71°C)

Construction Materials

See Table 1

Mounting

Actuator Yoke, Actuator Housing, Panel, Surface (Wall), or 2-inch Pipestand



Figure 1. Model 3350 Internals

1. If the supply gas is flammable or noxious, the controller must be located in a well-ventilated, non-hazardous area.
2. If this pressure is exceeded, control performance may be impaired.
3. At proportional band setting of 0 or 10.
4. At proportional band setting of 5.

Installation:

Model 3350 / 3360 controllers can be installed a number of different ways, as specified on page 2 ("Mounting"). The most common method is mounting the controller on a control valve yoke. When the controller is mounted in this manner, a supply regulator (Mallard Model 5601 recommended) is typically mounted on the opposite side of the actuator yoke (Figure 2). Alternatively, the supply regulator can be nipple-mounted to the controller. When the opposite side of the actuator yoke is occupied by a positioner or other device, nipple-mounting of the supply regulator is required.

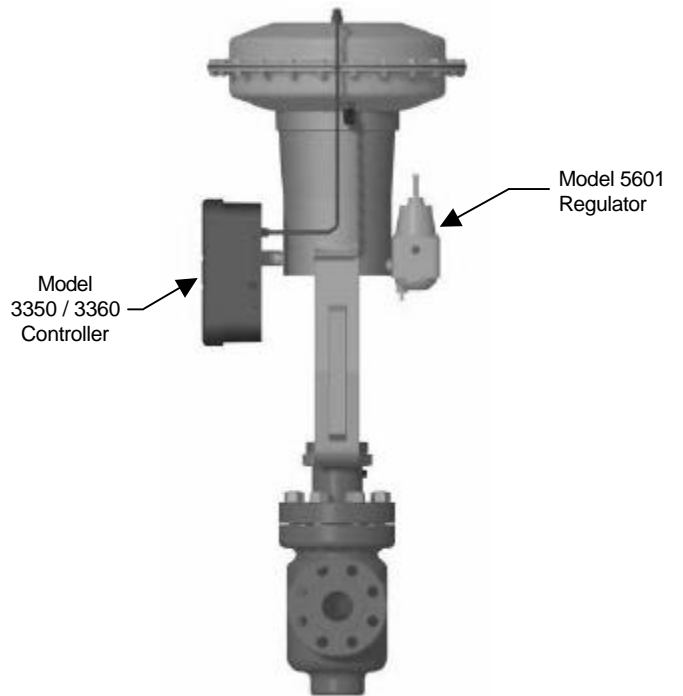

Figure 2. Yoke-Mounted Controller and Regulator

Dimensions:

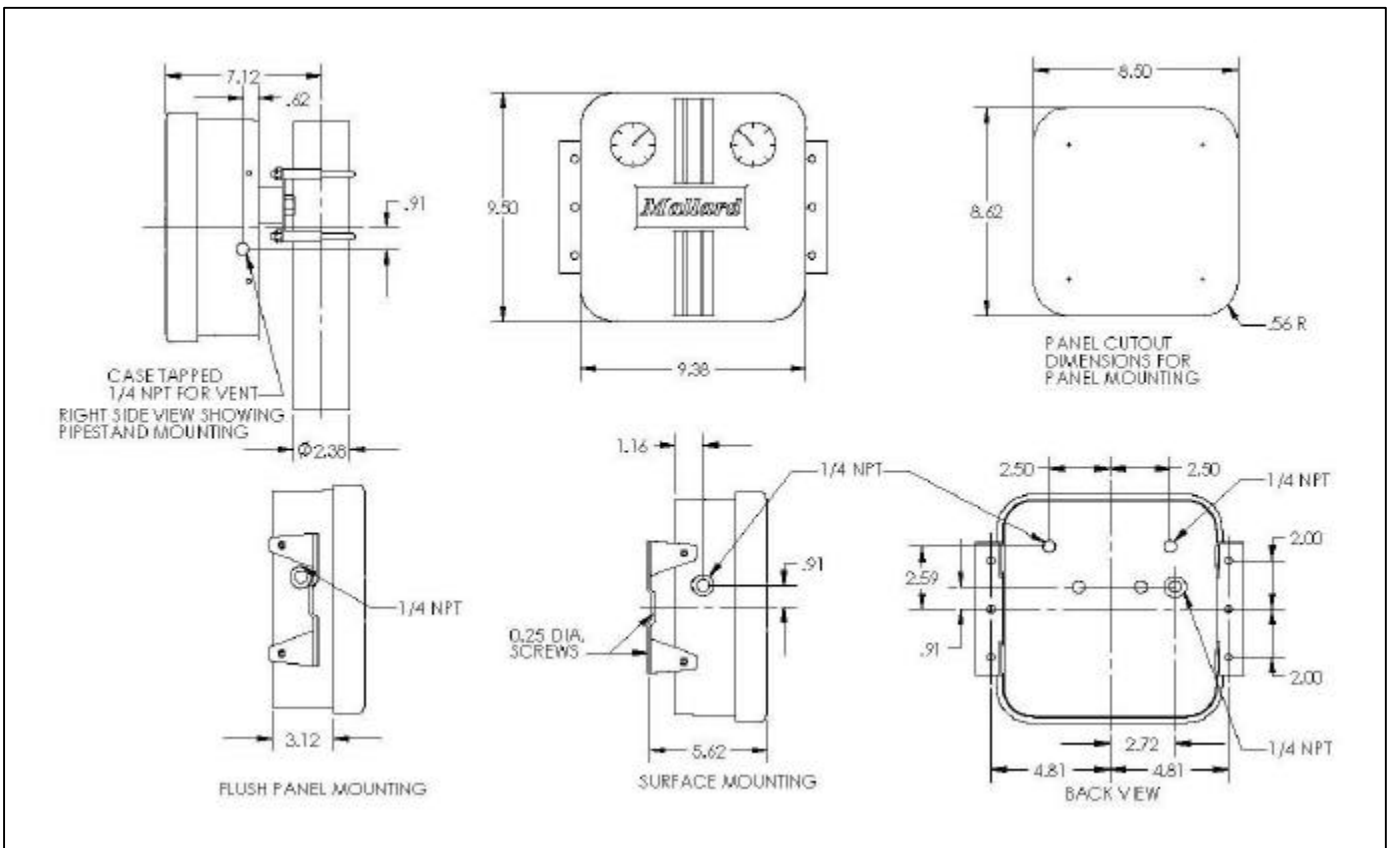

Table 1. Construction Materials

	Part	Material
Parts in contact with process fluid	Bourdon Tube	316 SST (std) or Monel ¹ (NACE option)
	Pressure Block	Zinc-plated Steel
	Input Pressure Tubing	316 SST
Parts in contact with operating supply medium	Supply and Output Tubing (internal)	Stainless steel
	Nozzle	Stainless steel
	Reversing Block	Aluminum
	Relay	Aluminum / stainless steel / steel
	Proportional Band and Reset	Aluminum / stainless steel
	Bellows	Brass (std) or stainless steel (sour gas option)
	O-Rings	Buna-N
	Gaskets	Neoprene
Other	Case and Cover	Die-cast Aluminum
	Mounting Bracket	Cadmium-plated steel (std) or 316 SST (optional)

1. Monel bourdon tubes available for 0–600 psig, 0–1000 psig, and 0–1500 psig ranges only.

Model Number Information

Sample Model Number: **3350 - 010 R 1 - 0**

CONTROLLER MODE	CODE
Proportional	50
Proportional-plus-Reset	60
INPUT SIGNAL RANGE	CODE
0 to 30 psig (0 to 2 bar)	003
0 to 60 psig (0 to 4 bar)	006
0 to 100 psig (0 to 7 bar)	010
0 to 200 psig (0 to 14 bar)	020
0 to 300 psig (0 to 20 bar)	030
0 to 600 psig (0 to 40 bar)	060
0 to 1000 psig (0 to 70 bar)	100
0 to 1500 psig (0 to 100 bar)	150
0 to 3000 psig (0 to 200 bar)	300
CONTROLLER ACTION	CODE
Direct (Increase output on increasing pressure)	D
Reverse (Decrease output on increasing pressure)	R
CONTROLLER OUTPUT	CODE
3-15 psig (0.2 to 1.0 bar)	1
6-30 psig (0.4 to 2.0 bar)	2
MOUNTING	CODE
None	-
NACE Compliant for Sour Gas Service	N
OPTIONS	CODE
None	0
Actuator Yoke	1
Actuator Housing	2
Panel	3
2-inch Pipestand	4
Surface (Wall)	5

While this information is presented in good faith and believed to be accurate, Mallard Control Company does not guarantee results based upon such information. Mallard Control Company reserves the right to change the design or specifications of these products without notice.

Mallard Control Company, Inc.

P.O. Box 7544
Beaumont, Texas, USA 77726-7544