

The Mallard Glass Liquid Level Gauge is a rugged flat glass gauge for medium-pressure (Model 3520) and high-pressure (Model 3540) applications. Standard construction includes a solid one-piece chamber machined form bar, forged steel covers, alloy steel bolts and nuts, and tempered glass. The Model 3520 / 3540 is available in a variety of materials to meet specific corrosion conditions.

Features:

- **Quality Materials** – Tempered borosilicate glass conforms to BS3463, JIS B8211, Din 7080, and DIN 7081. All parts are ASTM grade and listed in ANSI 31.3.
- **Quality Assurance Testing** – All gauges are hydrostatically tested to 1.5 times the rated pressure at 100°F (38°C).

- **No-Leak Design** – Recessed gasket seat in chamber and cover prevents leaks often caused by shifting gaskets.
- **Liquid-Gas or Liquid-Liquid Interface Applications** – Available in either reflex (Figure 1) or transparent (Figure 2) styles to satisfy all application requirements.
- **NACE Compatible** – Wetted parts conform to NACE MR-01-75 specifications for sour gas service.
- **Marine Option** – 316 SST bolts and nuts plus three-coat paint system, for optimal protection against corrosive environments.



Figure 1. Model 3520, Reflex Style Gauge Glass



Figure 2. Model 3520, Transparent Style Gauge Glass

SPECIFICATIONS:**Connections**

Standard: 1/2" or 3/4" Top – Bottom
 Optional: 1/2" or 3/4" Side – Side

Pressure / Temperature Ratings

Model 3520: See Table 1
 Model 3540: See Table 2

Gauge Length

See Table 3

Gauge sections are available in nine standard glass sizes. For longer size requirements, units are constructed with multiple vision slots in a continuous solid bar chamber.

Gauge Weight

See Table 3

Construction Materials**Liquid Chamber**

- Standard: ASTM A696 Gr. "C" Carbon Steel
- Optional: 316 SST, 316L SST, Monel, and Brass.

Cover: A105 Forged Carbon Steel

Bolts and Nuts

- Standard: A193 B7 and A194 2H alloy steel, "black oxide" treated to prevent rust.
 - Optional: 316 SST (Marine option)
- Glass: Tempered Borosilicate (to 600°F) or Aluminosilicate (to 800°F)
- Gaskets: Bonded Compressed Fibers or Glass Filled PTFE

Dimensions

Page 3

Table 1. Pressure / Temperature Ratings – Model 3520

Temp (°F)	Maximum Pressure (psi)																	
	Reflex Gauge									Transparent Gauge								
	Glass Size									Glass Size								
	1	2	3	4	5	6	7	8	9	1	2	3	4	5	6	7	8	9
100	3270	3140	3000	2880	2750	2630	2510	2390	2250	2000	1850	1750	1600	1500	1350	1250	1100	1000
200	3090	2970	2860	2740	2620	2500	2380	2260	2150	1900	1780	1660	1550	1440	1300	1175	1060	950
300	2900	2790	2670	2560	2450	2340	2220	2110	2000	1770	1660	1550	1450	1330	1220	1100	1000	900
400	2700	2600	2490	2380	2270	2170	2060	1950	1850	1675	1575	1470	1350	1250	1150	1050	925	850
500	2510	2410	2305	2205	2100	2000	1900	1800	1700	1530	1450	1350	1250	1150	1050	950	850	750
600	2285	2190	2100	2010	1915	1820	1730	1640	1550	1350	1275	1180	1100	1010	925	850	750	675
	Saturated Steam rating 300 WSP ¹									Saturated Steam using Mica 750 WSP ¹								

1. For temperatures above 600°F, aluminosilicate glass MUST be used.

Table 2. Pressure / Temperature Ratings – Model 3540

Temp (°F)	Maximum Pressure (psi)	
	Reflex Gauge	Transparent Gauge
	Glass size 1 thru 9	Glass size 1 thru 9
100	4000	3000
200	3890	2920
300	3790	2850
400	3700	2780
500	3470	2600
600	3080	2310
	Saturated Steam rating 300 WSP ¹	Saturated Steam using Mica 750 WSP ¹

1. For temperatures above 600°F, aluminosilicate glass MUST be used.

Table 3. Gauge Lengths / Weights

Length Code	No. of Sections	Glass Size	Visible Range	Overall Length	Approximate Weight	
					Reflex	Transparent
			In	In	lb	lb
11	1	1	3 3/4	5 1/4	8	10
12		2	4 3/4	6 1/4	9	14
13		3	5 3/4	7 1/4	11	17
14		4	6 3/4	8 1/4	12	19
15		5	7 7/8	9 3/8	14	21
16		6	9 1/8	10 5/8	16	24
17		7	10 1/4	11 3/4	18	27
18		8	11 7/8	13 3/8	20	30
19		9	12 5/8	14 1/8	21	32
23	2	3	13	14 1/2	22	33
24		4	15	16 1/2	25	38
25		5	17 1/4	18 3/4	28	43
26		6	19 3/4	21 1/4	32	49
27		7	22	23 1/2	35	54
28		8	25 1/4	26 3/4	40	61
29		9	26 3/4	28 1/4	43	64
36	3	6	30 3/8	31 7/8	48	73
37		7	33 3/4	35 1/4	53	80
38		8	38 5/8	40 1/8	60	92
39	4	9	40 7/8	42 3/8	64	97
47		7	45 1/2	47	71	107
48		8	52	53 1/2	80	122
49	5	9	55	56 1/2	85	129
57		7	57 1/4	58 3/4	88	134
58		8	65 3/8	66 7/8	100	152
59	6	9	69 1/8	70 5/8	106	161
68		8	78 3/4	80 1/4	120	187
69	7	9	83 1/4	84 3/4	127	196
78		8	92 1/8	93 5/8	140	221
79	8	9	97 3/8	98 7/8	148	230
88		8	105 1/2	107	160	254
89	9	9	111 1/2	113	169	265

DIMENSIONS

Top-Bottom Connections

To obtain maximum gauge length permissible for a **given vessel center-to-center** dimension:

$$\left(\begin{array}{c} \text{Valve} \\ \text{Center-to-Center} \\ \text{Dimension} \end{array} \right) - \left(\begin{array}{c} \text{Dimension} \\ \text{"A"} \end{array} \right)$$

To determine **overall length of nipples** needed to make up a gauge set for a **given vessel center-to-center** dimension:

$$\left(\begin{array}{c} \text{Valve} \\ \text{Center-to-Center} \\ \text{Dimension} \end{array} \right) - \left(\begin{array}{c} \text{Overall} \\ \text{Length} \end{array} \right) + \left(\begin{array}{c} \text{Dimension} \\ \text{"B"} \end{array} \right)$$

Overall nipple length can be divided between nipples to suit the application. Minimum length required for each nipple is 1 1/8" for 1/2" NPT nipple and 1 3/8" for 3/4" NPT nipple.

Side-Side Connections

To obtain vessel center-to-center dimension for a **given gauge length** with valves offset toward the gauge center:

$$\left(\begin{array}{c} \text{Overall} \\ \text{Length} \end{array} \right) - \left(\begin{array}{c} \text{Dimension} \\ \text{"C"} \end{array} \right)$$

To obtain vessel center-to-center dimension for a **given gauge length** with valves offset away from the gauge center:

$$\left(\begin{array}{c} \text{Overall} \\ \text{Length} \end{array} \right) + \left(\begin{array}{c} \text{Dimension} \\ \text{"C"} \end{array} \right)$$

Model	Dim. "A"		Dim. "B"		Dim. "C"	
	1/2" NPT	3/4" NPT	1/2" NPT	3/4" NPT	1/2" NPT	3/4" NPT
3500	2 7/8"	3 1/8"	5/8"	7/8"	1 1/2"	1 7/8"
3510	6 1/8"	6 3/8"	3 7/8"	4 1/8"		

Model Number Information**Sample Model Number: 3520 - 15 R B1 - 1 S**

RATING – see Page 2	CODE
Medium Pressure (Table 1)	20
High Pressure (Table 2)	40
LENGTH CODE – see Table 3	CODE
(example)	15
STYLE	CODE
Reflex	R
Transparent	T
CONNECTION	CODE
1/2" Top – Bottom	B1
3/4" Top – Bottom	B2
1/2" Side – Side (Close-hookup)	C1
3/4" Side – Side (Close-hookup)	C2
MOUNTING	CODE
None	0
Style 1	1
Style 2	2
Style 3	3
Style 4	4
COATING OPTION	CODE
Standard	S
Marine	M

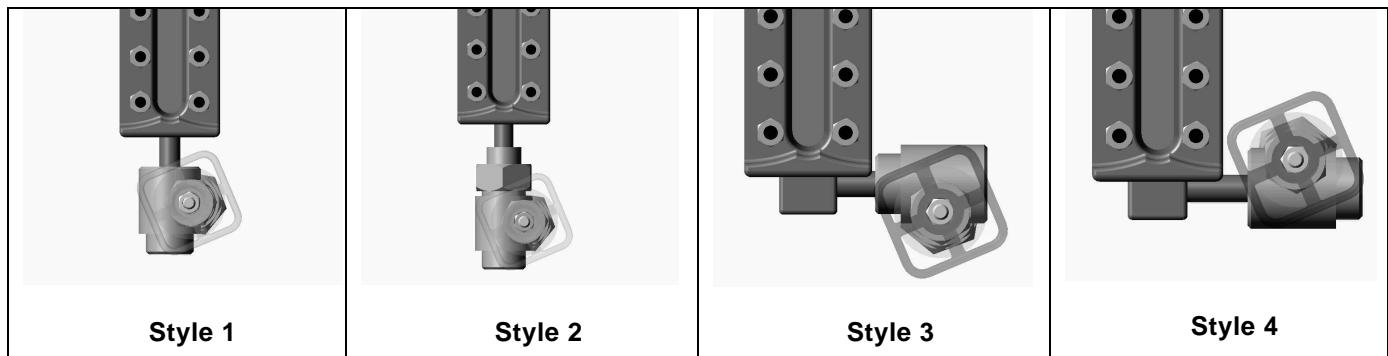
MOUNTING OPTIONS

While this information is presented in good faith and believed to be accurate, Mallard Control Company does not guarantee results based upon such information. Mallard Control Company reserves the right to change the design or specifications of these products without notice.

Mallard Control Company, Inc.

P.O. Box 7544
Beaumont, Texas, USA 77726-7544