

The Model 3100P (Figure 1) and 3100P1 (Figure 2) are pneumatic, float-operated switches for liquid level control. The 3100P is a 2-way normally-open or normally-closed pneumatic switch, and the 3100P1 is a 3-way block-and-bleed switch. The 3100P and 3100P1 are rated for high pressure applications, and the polystyrene float will effectively and consistently operate the switch at specific gravities as low as 0.50. Both models can be mounted directly onto the vessel nozzle or into an external float chamber (Figure 3).

Specifications

- Process Connections: 2" MNPT
- Operating Pressure (Max.): 1500 psig (103 Bar)
- Operating Temperature: -20 to 300°F (-29 to 200°C)
- Supply Pressure Connection: 1/8" FNPT
- Exhaust Connection: 1/4" FNPT
- Supply Pressure: 30 to 60 psig

Materials of Construction

- Body: 1018 Carbon Steel, cadmium-plated
316 SST (NACE option)
- Float: Polystyrene
316 SST (Hi temp option) - 0.68 SG min.
- Seals: Viton

Replacement Parts

- 31008 Flapper
- 31038 Cam
- 31126 Polystyrene Float
- 31128 Optional SST Float
- 31040 Valve Stem
- 85020 Valve Seat Assembly, includes:
 - 31044 Valve Seat
 - 31046 Viton Seat
 - 31048 Adjusting Nut
 - 31042 Valve Actuator Spring
 - 31010 Set Screw
- 85022 Counter Balance Assembly, includes:
 - 31032 Counter Balance
 - 31026 Pivot Tube
 - 31002 Hinge Pin
 - 31012 Nylon Washers (2)

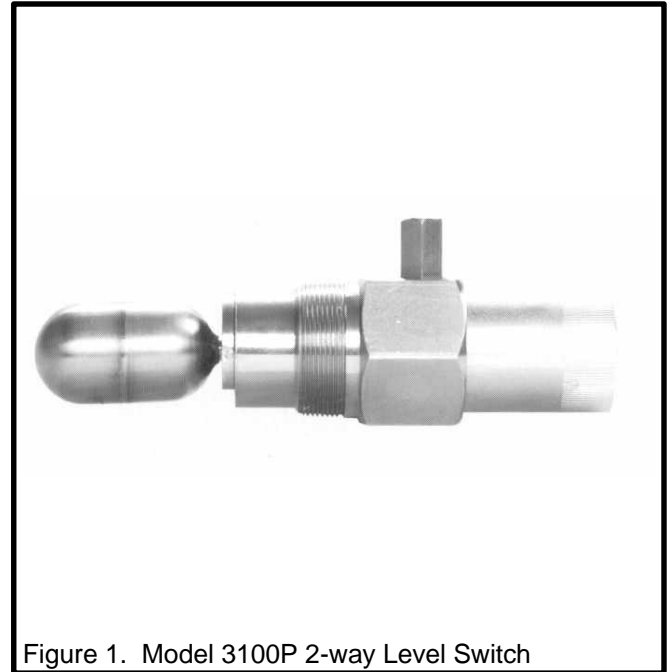

Figure 1. Model 3100P 2-way Level Switch

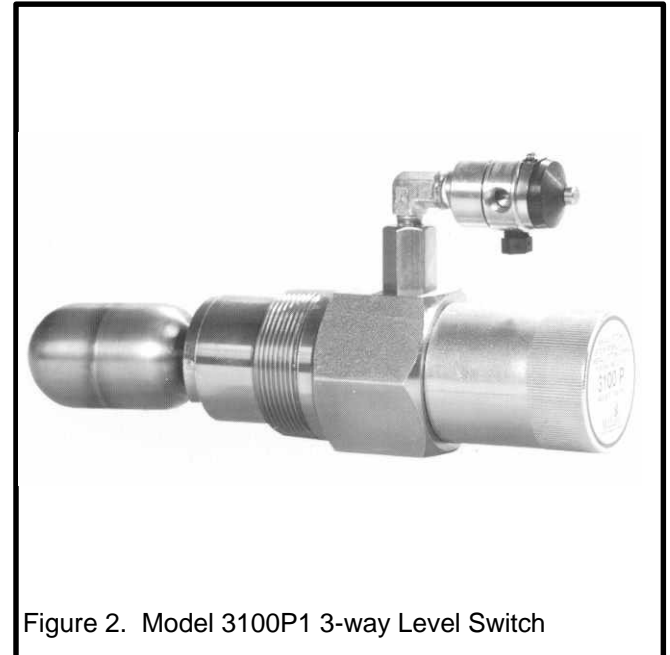
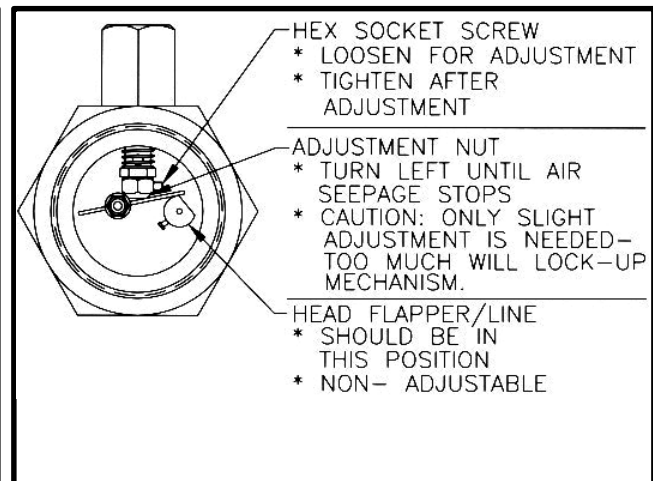
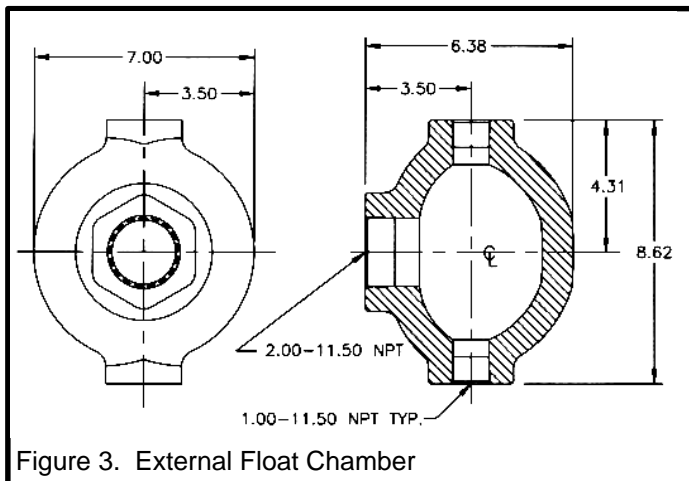
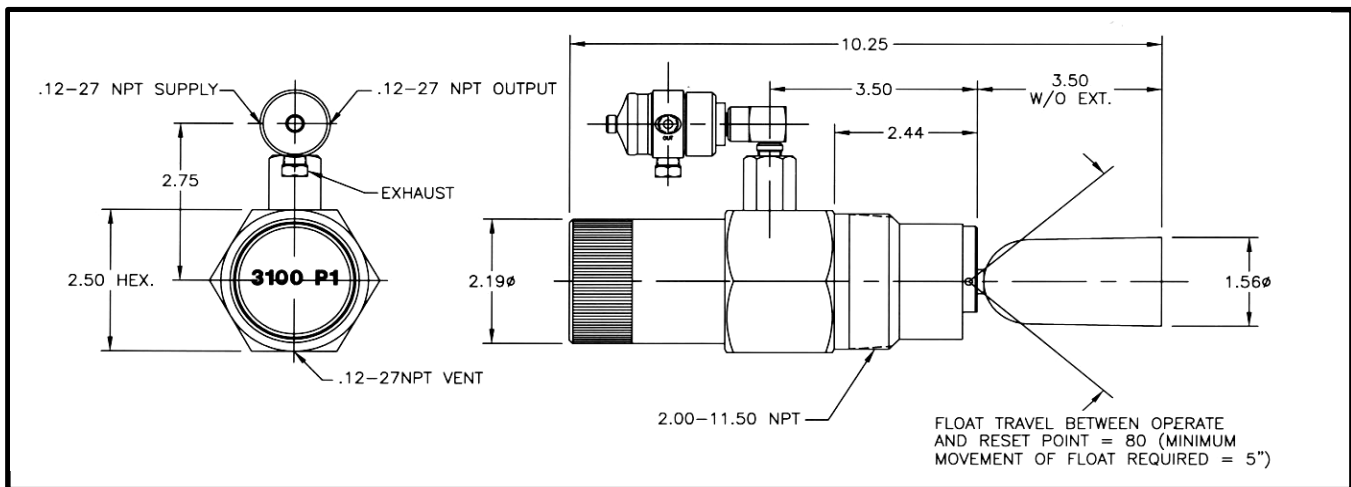
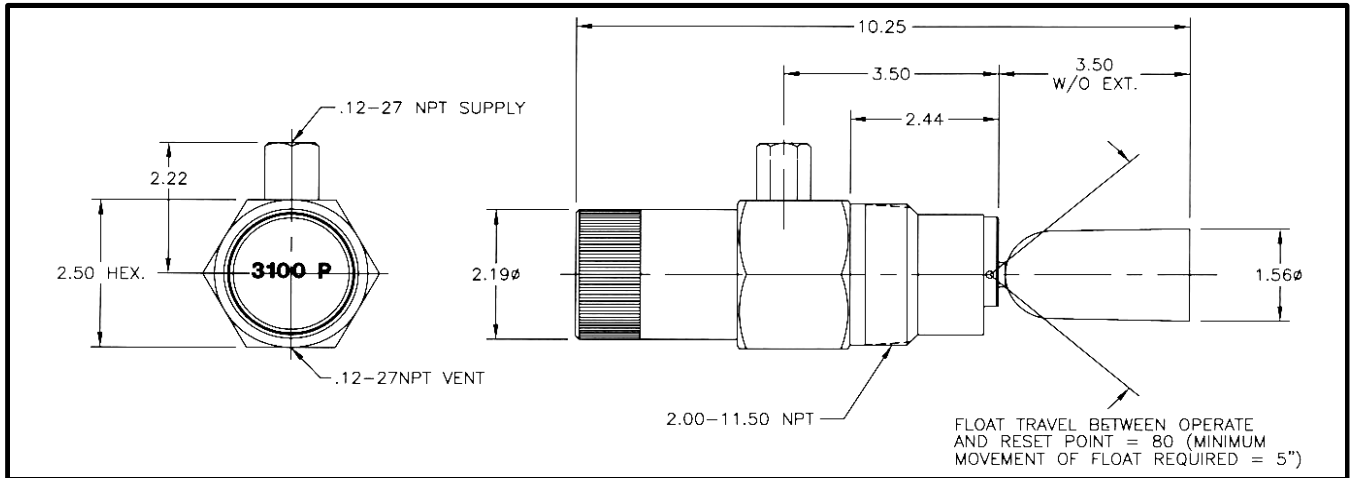

Figure 2. Model 3100P1 3-way Level Switch

Standard Model	Description
3100P	2-Way Float Switch - CS
3100P1	3-Way Float Switch - CS
3100P-SS	2-Way Float Switch - SST
3100P1-SS	3-Way Float Switch - SST

Options	
Part Number	Description
31128	SST Float, 0.68 SG
31124	External Float Chamber
31130	1" Float Extension

DIMENSIONS



While this information is presented in good faith and believed to be accurate, Mallard Control Company does not guarantee results based upon such information. Mallard Control Company reserves the right to change the design or specifications of these products without notice.

Mallard Control Company, Inc.

P.O. Box 7554

Beaumont, Texas, USA 77726-7554

Listed by www.ValveDepot.com